

PTG-42MD

STANDARD CONSTRUCTION:

Frame: 4" deep, 6063-T6 extruded aluminum. .125" nominal wall thickness.

Blade: 6063-T6 extruded aluminum .064" nominal wall thickness. Blades are positioned at a 42 deg. angle at 0.75" centers

Finish: MILL

Minimum Size: 42.25"W x 16.25"H

Maximum Size: 80.00"W X 30.25"H

Performance

- 57.56% Free Area at 42" x 16"
- Design Load: +150, -150 psf & Impact rated

Available Finishes

- Kynar (2 coat & 3 coat)
- Prime Coat
- Clear and Color Anodized.

(Variation in anodized material is possible)



**Dade County Approved
 NOA #23-1017.02**

Contact Air Performance for any additional information or special requirements.

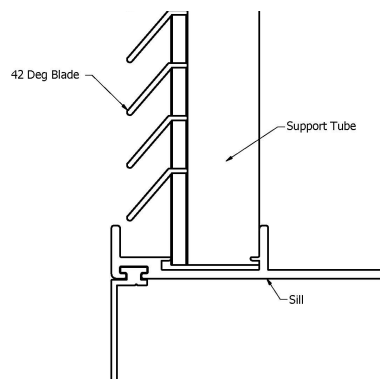
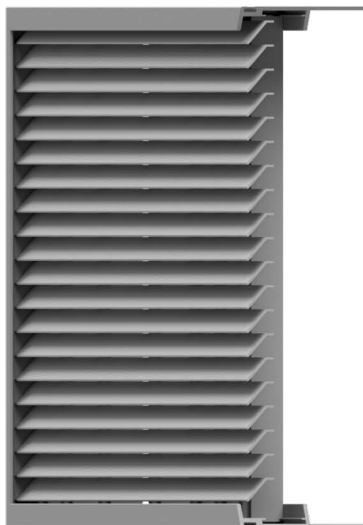
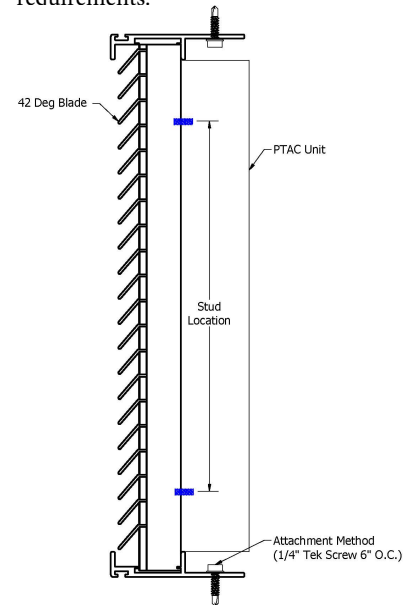
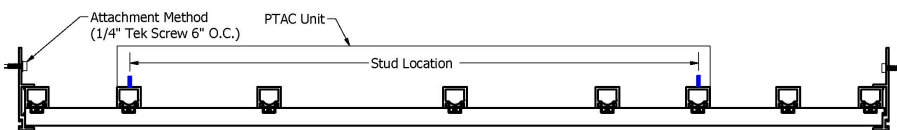

Flange Adapter Option

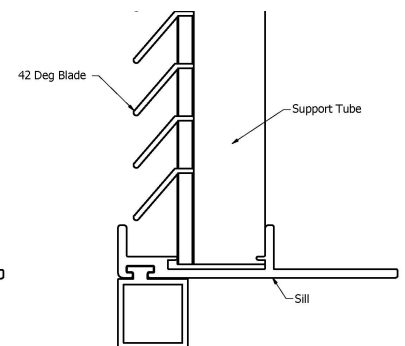

Glazing Adapter Option
 (Other glazing adapters available)